

CEM-24 Series

Thermostat

Application

The CEM series is a telephone communication thermostat used in commercial, residential or industrial buildings. Excellent for access to remote facilities via the telephone to check and adjust operating parameters. Also for people with vacation homes that want to check their home or condominium to make adjustments before they arrive. Additional telephone line not required, works with answering machine. Thermostat and modem in same enclosure.



General Description

- ◆ **Surface Mount Programmable 5/1/1 Thermostat, 24 VAC or Non-Programmable**
- ◆ **Large LCD Display, Easy to Read and Program**
- ◆ **Displays both Room and Set Point Temperature Simultaneously**
- ◆ **Built in Auto Changeover or Manual**
- ◆ **Compressor Short Cycle Protection**
- ◆ **"All in one", SUPER Configuration, Heat Pump, Gas/Electric, Multi-stage, (Reduce Inventory) Optional**
- ◆ **For Heat Pump Models, Energize Reversing Valve with "B" or "O" Terminal**
- ◆ **Unoccupied Function ("One Touch" Feature, Adjustable)**
- ◆ **External Temperature Sensing**
- ◆ **Outdoor Temperature Sensing**
- ◆ **Temperature Averaging**
- ◆ **Fully Electronic for Accurate Control and more Comfort**
- ◆ **Battery Back-up for program**
- ◆ **Meets Title 24 Residential Requirements in California**
- ◆ **Proven Reliability Backed by the World's Most Experienced Manufacturer of Air Conditioning and Heating Controls**
- ◆ **Set-point Limits, password protected**
- ◆ **Low & High Temperature Alarm Output**

We Make Life More Comfortable



**Systems
Controls &
Instruments**

1-877-662-0660 www.scillc.com

Typical Layouts

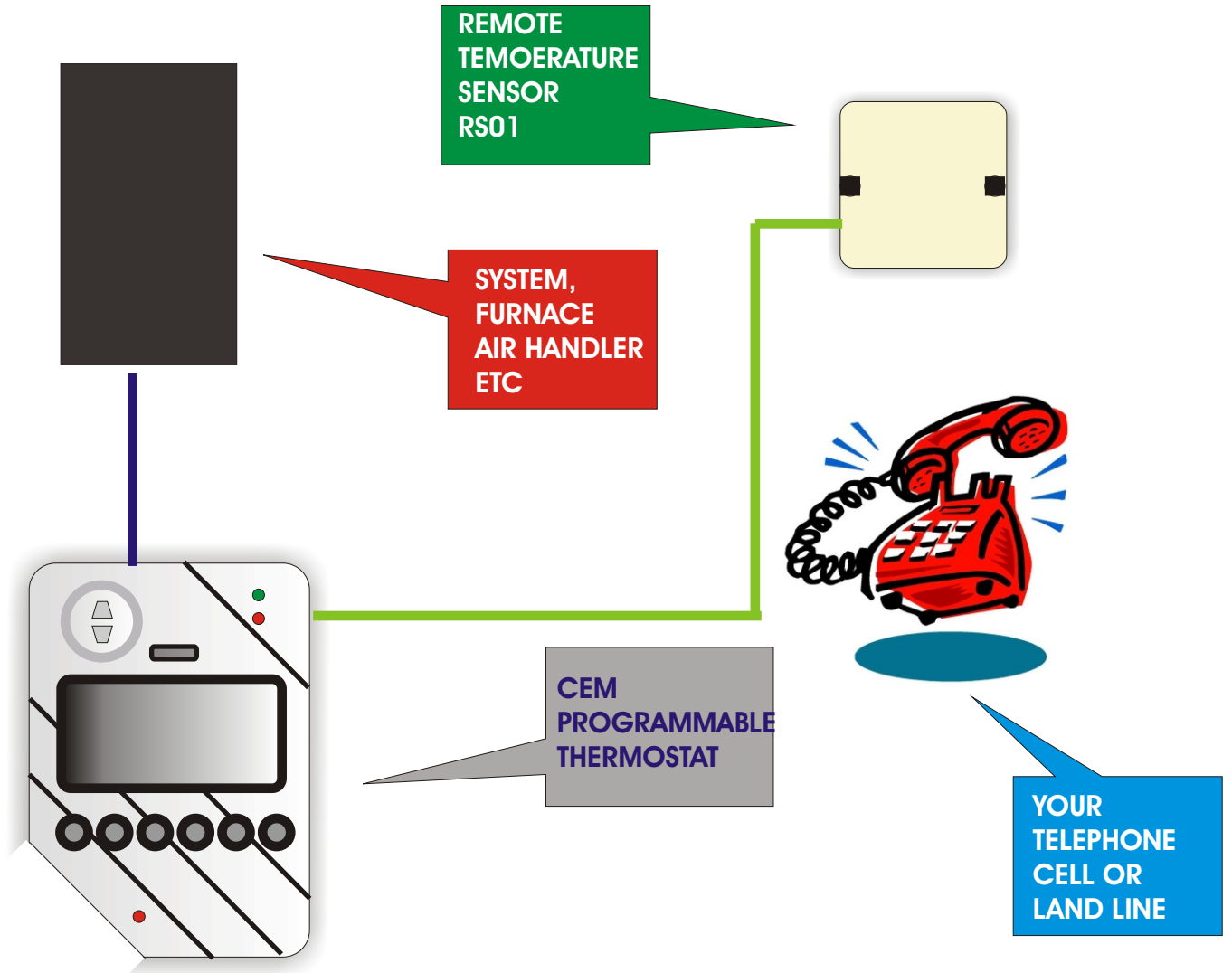

**Systems
Controls &
Instruments, L.L.C.**

**GIVE IT A TRY
888-588-7113
PASSWORD: 1234#**

1-877-662-0660 www.scillc.com